



Active Cycle of Breathing Techniques

Active Cycle of Breathing Technique

Active Cycle of Breathing Technique (ACBT) is used to clear secretions from the lungs. It can also help to improve lung function.

There are three types of breathing techniques that you will need to learn;

- **Breathing Control (BC):** Normal gentle breathing with a pause after breathing in. Use the lower chest; relax your shoulders and upper chest.
- **Thoracic Expansion Exercises (TEE):** Deep breath in and hold for 2-3 seconds. Breathe out easily without force.
- **Forced Expiration Technique (FET):** This is a “Huff/ Cough” technique that is a slow inhalation using the lower chest and follow with a forced exhalation without closing the throat. When the mucus has reached the upper airway, cough to clear the secretions.

Positions can be changed to let gravity help drain the mucus during the treatment. ACBT should never feel bad and it can be changed and varied until the huff/ cough is dry sounding and/or no more mucus is coughed up. Ten minutes of ACBT is a minimum time for an effective treatment. Twenty to thirty minutes would be best.

Active Cycle of Breathing Technique Cycles

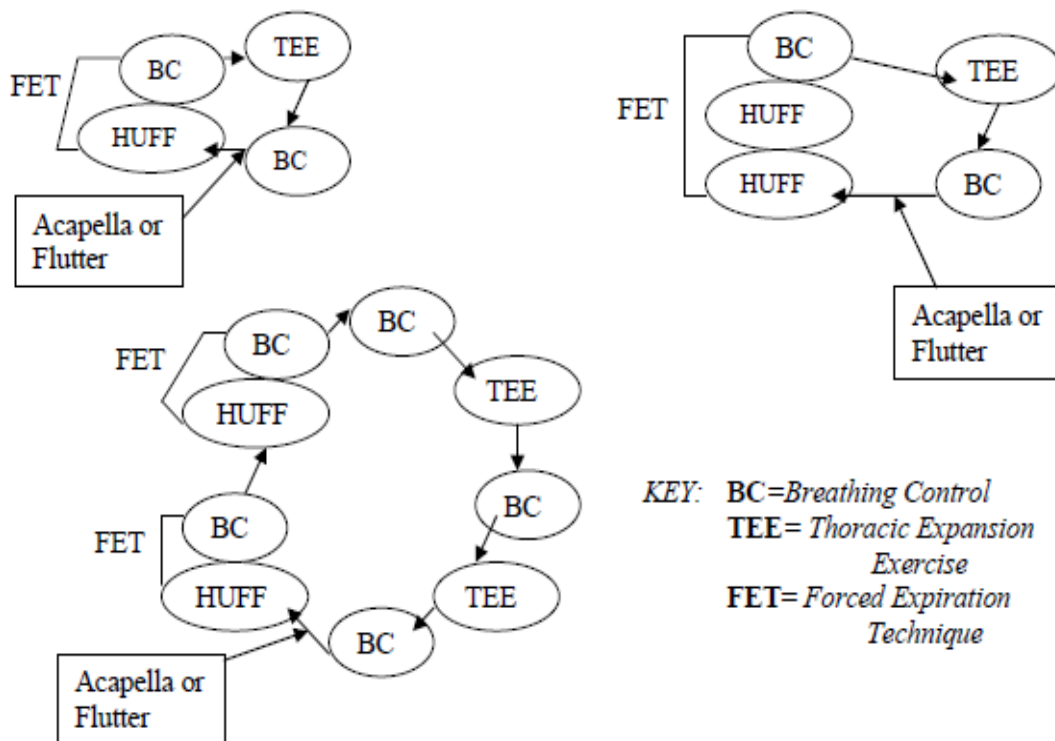

Choose the cycle example that is most effective for you.

To increase the effect of ACBT, add 3-5 breaths on your Acapella or Flutter device before the Huff Cough in each cycle. 10 cycles of ACBT and Acapella or Flutter equals a full Airway Clearance session.